

BioSand Filter - Information Sheet

Friends Who Care Charities Ltd

Rod and Ingrid McCarroll, Directors

fwc@friendswhocare.ca www.friendswhocare.ca

Mexico Cell: 044-331-118-2876

The BioSand filter is a 'point of use' device. The water to be filtered can be obtained from the closest water supply point, whether river, stream or well, carried physically to the filter and used immediately thereafter. The water supply, water treatment and water distribution are therefore all within the control of the individual householder



Design Parameters

- Household (6-15 users)
 - Concrete filter body
 - 60 litres/hour or 1 litre per minute
 - Specific Loading Rate- 10 litres/min/m²
 - Adaptation of slow sand filter technology
- Intermittent Operation
 - Shallow and constant water layer
 - Run and pause periods (water level maintained during pause)
- Consistent supply water quality
- Intermittent Cleaning
- Flow rate controlled by sand size (Sieving and washing)
- Pause period (Micro-organisms consume pathogens - bacterivore)
- Water – Sand levels
 - Too shallow – biolayer dries out
 - Too deep – insufficient oxygen for biolayer
- Start up time required to establish biological layer
- Maintenance
 - Ensure cleanliness of filter body and spout
 - Simple agitation process to restore flow rate
- Filtered water quality
 - > 90 % removal efficiency
 - Disinfection recommended

Removal Mechanisms

- Combination of biologic and mechanical
- Fine sand traps organic material at surface of sand and forms a layer where micro organisms grow
- 4 main mechanisms
 - Mechanical trapping between pores
 - Adsorption – onto each other and on to sand grains
 - Predation- bacterivore
 - Natural death of pathogens

Start-up Time

It normally takes a period of one to three weeks for the biological layer to develop to maturity in a new filter. During that time, the removal efficiency of the filter increase as the biological layer grows.

Water Source

The water supplied to the filter can be from rain water, deep wells, shallow wells, rivers, lakes, reservoirs or surface water. It should be consistently taken from the same source.

The turbidity or amount of suspended particles in the water is also a key factor in the operation of the filter. It should be relatively free of suspended particles to prevent premature fouling of the filter. If the turbidity is greater than 50-100 NTU, the water should be pre filtered before it goes through the BioSand filter.

Flow Rate

The BioSand filter has been designed to allow for a filter loading rate of 1 litre/minute which has proven to be effective in laboratory and field tests.

The amount of water that flows through the biosand filter is controlled by the size of sand media contained within the filter. If the rate is too fast, the efficiency of bacterial removal may be reduced. If the flow rate is too slow, there will be an insufficient amount of treated water available from the filter to meet the needs of the users.

Water Depths

Proper construction and correct operation of the BioSand filter will result in a constant water level over the pause periods.

Changes in the water depth above the sand surface will cause a change in the biological zone disrupting the efficiency of the filter. A water depth of greater than 5-8 cm results in lower oxygen diffusion and consequently a thinner biological zone. A high water level can be caused by a blocked outlet spout or by an insufficient amount of sand media. As the water depth increases, the oxidation and metabolism of the micro organisms within the biological zone decrease. Eventually the layer dies off and the filter becomes ineffective.

Correct operation of the BioSand filter requires a constant water level of approximately 5 cm (2") above the sand level during the pause periods.

Pause Periods

If the pause period is extended for too long, the micro-organisms will eventually consume all the substrate and then die. This results in a marked reduction in removal efficiency of the filter. The pause periods are also very important because they allow time for the micro-organisms in the biologic layer to consume the pathogens contained in the water, thereby increasing the hydraulic conductivity of the filter. Consequently, the BioSand filter is most effective and efficient when operated intermittently.

Filter Description

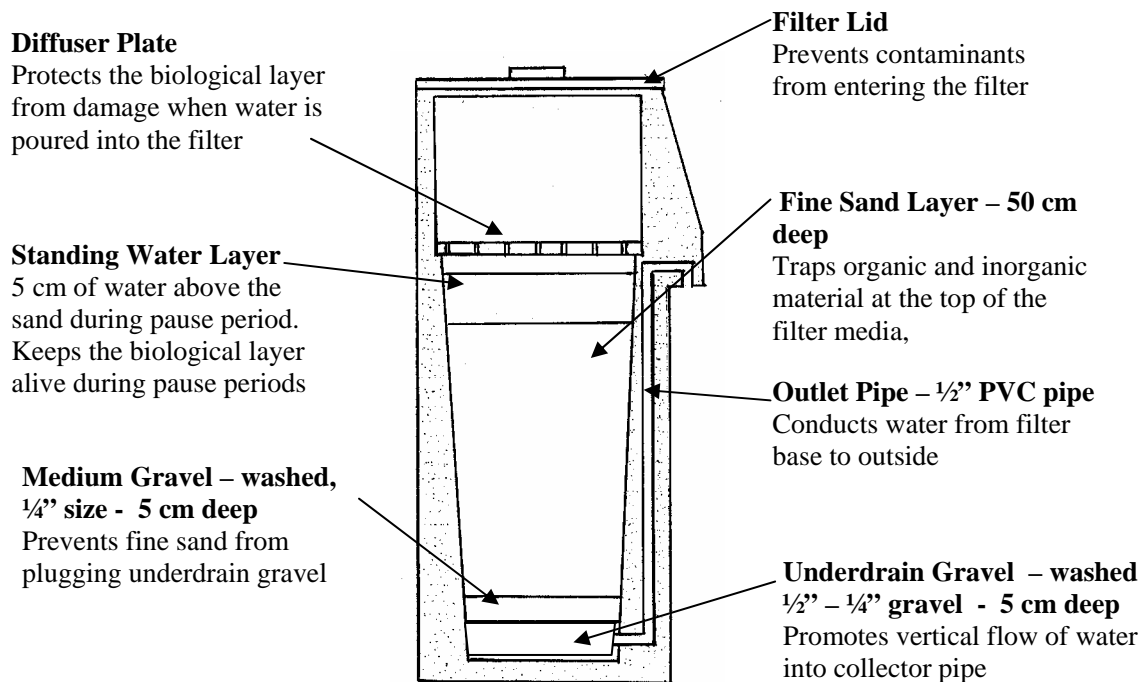

Fine Sand Filter Media

- Obtained from clean, crushed rock or quarry
- Screened through metal mosquito mesh screen
- Washed to ensure a Uniformity Coefficient of 1.5 – 3.0
- Non uniform sizing
- No beach sand; no river sand
- Avoid areas used by people or animals to ensure uncontaminated sand
- No substrate (clay, loam, organic material)

Concrete Filter Body

- Mix concrete (by hand or with mixer)
 - 2 part Type 10 Portland cement (approximately 40 kgs (88 lbs))
 - 3 part clean pea gravel (1/4")
 - 2 part clean sand
- weight when empty – 150 kgs (330 lbs)
- Weight when full of sand and water - 225 kgs (500 lbs)

Diffuser

- Required to prevent the disturbance of the sand surface when water is poured into the filter
- Can be made of various materials that are suitable to be submerged in water such as heavy plastic, acrylic, plexiglass, or galvanized metal.
- 100 holes, no larger than 3/16" diameter, are drilled or punched in the material on a 1" x 1" grid

Tightly fitting lid

- Prevents contamination of source water and unwanted pests
- Outside lip
- Can be made from various material usually wood or galvanized metal

Maintenance

The operation and maintenance of the filter are simple. There are no moving parts that require skill to operate. When the flow through the filter becomes too low, the maintenance consists simply of washing the top few centimetres of sand.

Over time, continued use of the filter causes the pore opening between the sand grains to become clogged with debris. As a result, the flow rate of water through the filter decreases.

To clean the filter, the surface of the sand must be agitated thereby suspending captured material in the standing layer of water. The dirty water can then be simply removed using a small container. The process can be repeated as many times as necessary to regain the desired flow rate. After cleaning, a re-establishment of the biological zone takes place quickly, returning the removal efficiency to the previous level.

Biosand Filter Limitations

- Cannot remove dissolved compounds (e.g. salt, hardness, arsenic, fluoride)
- Cannot guarantee bacteria free water (Lab testing shows removal efficiencies of 97 – 99.7 %; Field testing show removal efficiencies of 90 – 97 %)
- Recommended to use disinfection (bleach) in filtered water
- Cannot remove all organic chemicals (e.g. pesticides, fertilizers)
- Cannot removal all colour from inlet water